

Fill in blue boxes and click submit form

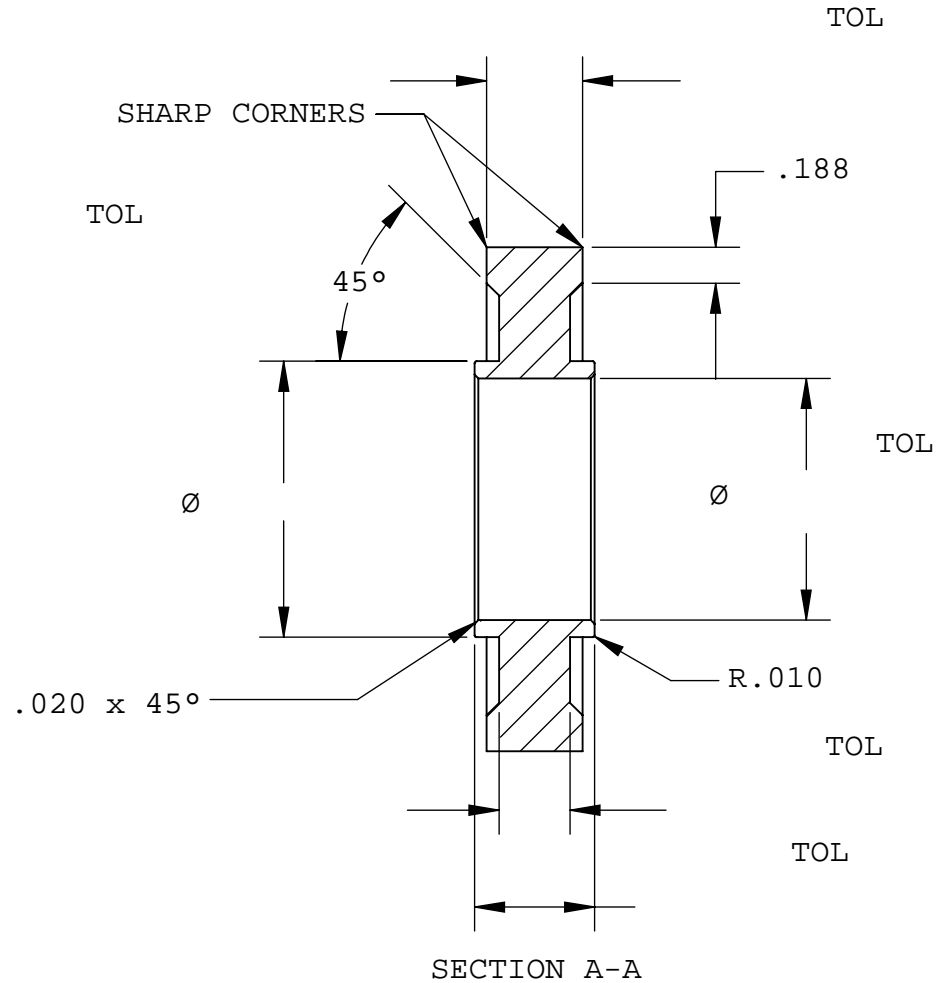
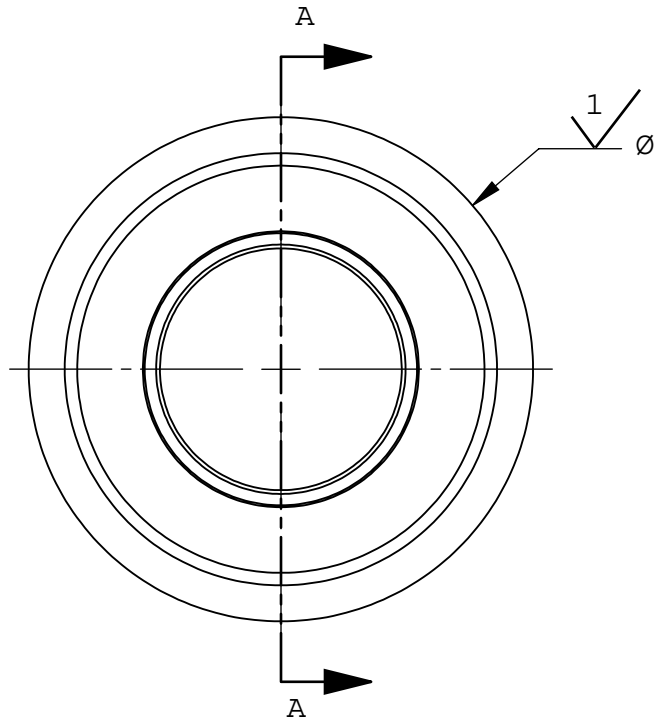

CUSTOMER
NAME
PHONE

PROPRIETARY AND CONFIDENTIAL
THE INFORMATION CONTAINED IN THIS DRAWING IS THE SOLE PROPERTY OF GLEN CARBIDE INC.. ANY REPRODUCTION IN PART OR AS A WHOLE WITHOUT THE WRITTEN PERMISSION OF GLEN CARBIDE INC. IS PROHIBITED.

		DIMENSIONS ARE IN INCHES TOLERANCES: EXCEPT AS NOTED FRACTIONAL ± .010 ANGULAR: ±0°15'		NAME	DATE	
		TWO PLACE DECIMAL ±.005 THREE PLACE DECIMAL ±.001 FOUR PLACE DECIMAL ±.0002		DRAWN		
		MATERIAL		CHECKED		3U TURKS HEAD ROLL
NEXT ASSY	USED ON	FINISH		ENG APPR.		
APPLICATION				MFG APPR.		
				Q.A.		SIZE A DWG. NO.
				COMMENTS:		SCALE:1:1 WEIGHT: SHEET 1 OF 1
						REV.